

# INSTRUCTIONS



27287-111 R

## LEICAFLEX SL 2

111-94/Engl.



**The LEICAFLEX® SL 2 is a modern single-lens-reflex camera with selective light metering through the lens. The large, bright LEICAFLEX viewfinder gives you all the necessary information. At the same time it functions as the control and composing centre for focusing, spot exposure measurement, assessment of the pictorial effect, and perspective. Both the shutter speed set on the dial and the lens stop can be read at the same time. All controls are arranged conveniently so that you will soon carry out the few operations almost in your sleep. But please spend a little time on reading these instructions: you will have even more fun when you take photographs with your new LEICAFLEX SL 2.**

## Contents

Brief description for the reader in a hurry	4	<b>Accessories for the LEICAFLEX SL 2</b>	
Inserting and changing the lens	6	Interchangeable lenses	28
Holding the camera correctly	7	Follow-focus lenses	30
The composing and control centre	8	LEICA lenses on the LEICAFLEX	30
Focusing	10	Focusing Bellows-R	31
Exposure meter	12	Motor for the LEICAFLEX SL2 MOT	31
Setting film speed and -type	13	Ring combination for the close-up range	32
Use of filters	16	ELPRO close-up attachments	32
Testing and changing the battery	17	Cases	34
Rapid transport lever, shutter speed dial, release button	18	Enlargers	34
The LEICAFLEX lenses	19	Projectors	35
Automatic diaphragm	19	LEITZ Warranty	36
Depth-of-field button	20	After-sales service	36
Depth-of-field scale	20	LEITZ Information Service	37
Lens hoods	21	"LEICA FOTOGRAFIE" journal	38
Series filters	22	Available accessories	39
Self-timer	22		
Flash synchronization, flash table	23		
Inserting the film	24		
Taking out the film	26		
Tips for the care and maintenance of the LEICAFLEX and its lenses	26		

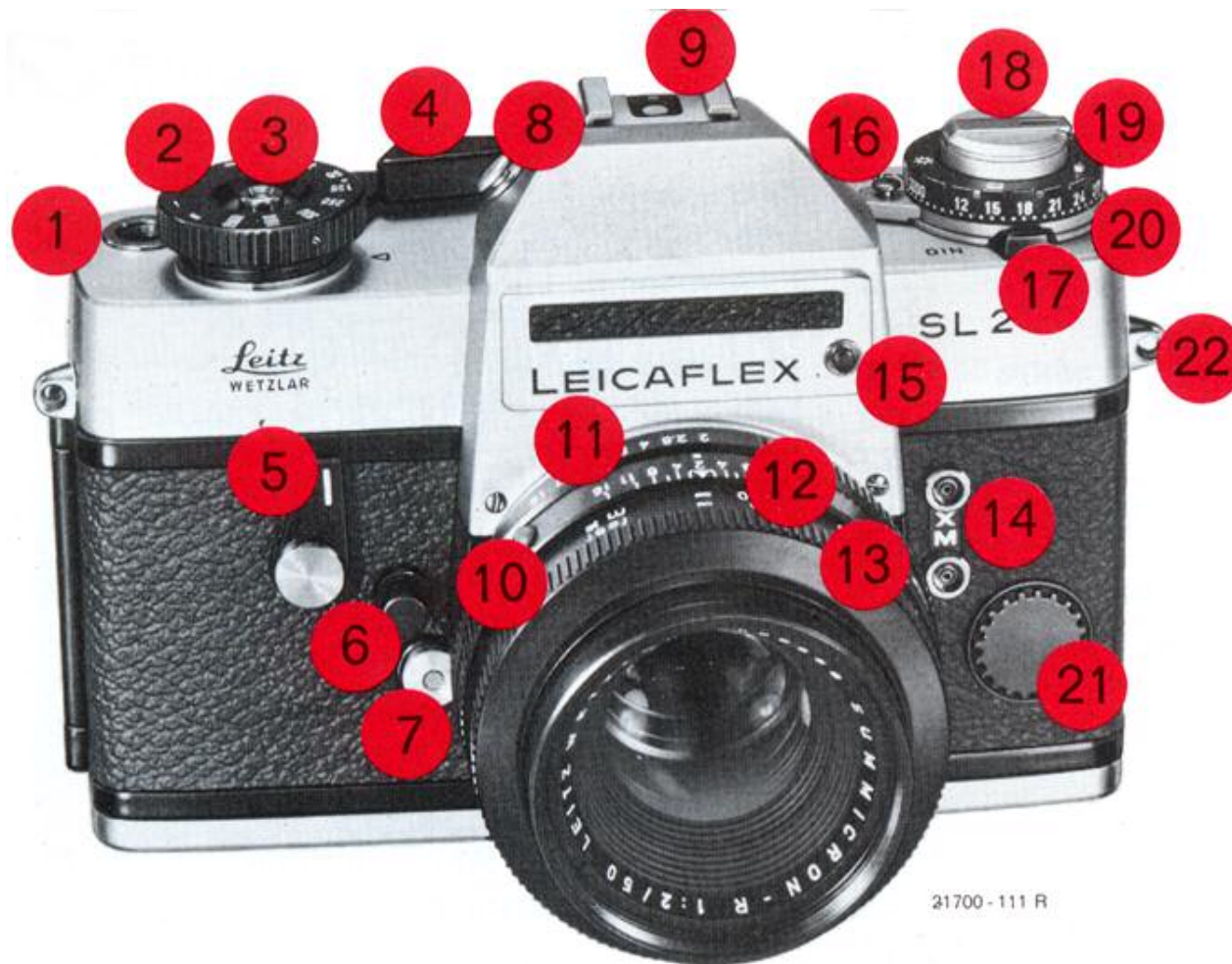

### Brief Description for the Reader in a Hurry

- 1 Automatic film counter (p. 24)
- 2 Shutter speed dial (p. 18)
- 3 Release button with thread for cable release (p. 18)
- 4 Rapid transport lever for shutter wind and film transport (p. 18), at the same time on/off switch of the exposure meter (p. 12)
- 5 Self-timer (delayed-action mechanism) (p. 22)

- 6 Depth-of-field button (p. 20)
- 7 Bayonet lock for the lens (p. 6)
- 8 Button for switching on the viewfinder illumination in poor lighting conditions (p. 15)
- 9 Accessory shoe with central contact (p. 23)
- 10 Red dot mark for lens change (p. 6)
- 11 Diaphragm pre-setting ring (p. 19)
- 12 Depth-of-field scale (p. 20)
- 13 Distance setting ring (p. 10)





- 14 Contact bushes for flash units (p. 23)
- 15 Button for testing the exposure meter battery (p. 17)
- 16 Locking button for DIN/ASA setting of the exposure meter (p. 13)
- 17 Clamp for pulling out the rewind crank to open the camera back (p. 25)
- 18 Swing-out rewind crank (p. 25)
- 19 Disc with film-type symbols (p. 13)
- 20 DIN scale (p. 13)
- 21 Cover of the battery for viewfinder illumination (p. 15)
- 22 Eyelets for the carrying strap (p. 7)
- 23 ASA scale (p. 13)
- 24 24 Cover for the exposure meter battery (p.17)
- 25 Viewfinder eyelens, accepts mount for correction lenses (p. 8)
- 26 ¼ in tripod bush
- 27 Push-button for rewind release (p. 25)



### Inserting the lens

For insertion of the lens in the bayonet ring on the camera body the red dot (10) on the lens mount must face the bayonet lock (7) marked in red. After a slight turn to the right the lens clicks into position. Change lenses in the shadow of your body.



### Taking out the lens

Irrespective of the distance and diaphragm settings the LEICAFLEX lenses are changed as follows: Grip the lens on the fixed ring (12), depress the bayonet lock (7), turn the lens to the left and take it out.



### **Holding the camera correctly**

For the steady 3-point support the right hand grips the camera. The index finger rests on the release button, the thumb against the rapid transport lever. The left hand supports the lens from below.

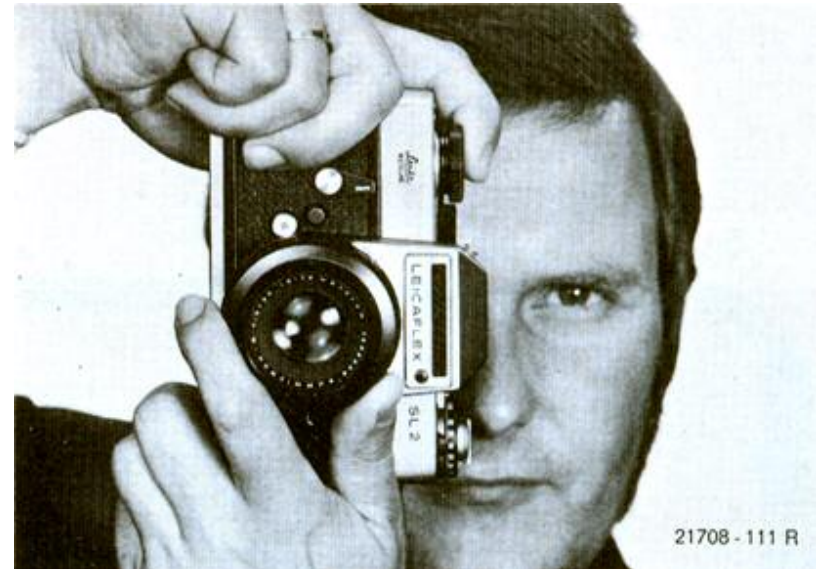

When taking pictures in the upright format, simply turn the LEICAFLEX. The hands remain in the same position as for horizontal pictures, ready to wind on the film and to focus.







### **The composing and control centre**

The viewfinder of the LEICAFLEX SL 2 is the centre both for pictorial composition and for control of all important data: sharpness, picture area and perspective, measuring field and exposure meter pointer, shutter speed set on the dial and lens stop.

Spectacle wearers, too, can normally survey the viewfinder image without difficulty. In special cases, correction lenses in a mount can be pushed onto the eyelens mount.

The viewfinder of the LEICAFLEX SL 2 has been adjusted with micro-precision. This ensures optimum sharpness as well as exact agreement of viewfinder image and picture area on the film.

A scale below the viewfinder field indicates on the left the shutter speed set on the dial, and on the right the pre-set lens stop.



28466 - 111 R

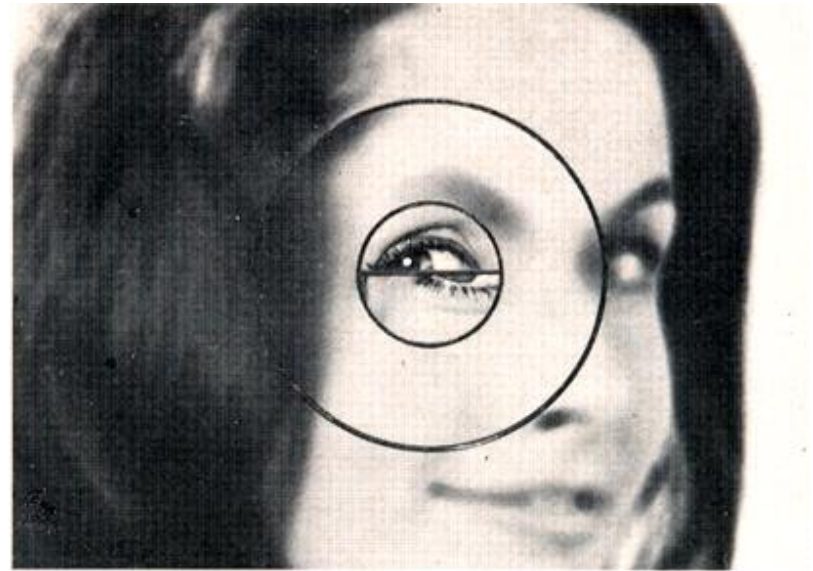

28465 - 111 R

## Focusing

According to your predominant photographic work you will have chosen between 3 permanently built-in viewfinder screens.

The image is focused by rotation of the distance setting ring (13) on the lens.

### a) Screen with split-image wedge

This screen is particularly suitable for quick focusing with wide-angle and standard lenses. Unless focusing is critical, edges and lines of the object are mutually displaced in the horizontal split image.

A ring-shaped quadrangular micro-prism

screen surrounds the central split image. This serves for the focusing of objects lacking crisp outlines. Out-of-focus setting is indicated by distinct flickering.

The surrounding field consists of triangular micro-prisms, producing a ground-glass screen effect. This surrounding field is therefore used mainly for focusing with longer-focal-length lenses and in the close-up range.



28467 - 111 R

**b) Screen without split-image wedge** The entire central measuring field is occupied by a quadrangular micro-prism screen. Distinct flickering indicates that the object sighted is not critically focused on this screen.

**c) Groundglass screen**

The image can be focused within the entire viewfinder field. The central circle indicates the measuring field for the exposure meter. This screen is suitable for close-up and macro-photography as well as for extreme telephoto work. In these cases the working stop is usually employed for focusing etc. because a transmission of the automatic diaphragm is no longer possible. The LEICAFLEX SL 2 MOT special version is supplied with a ground-glass screen unless otherwise ordered.

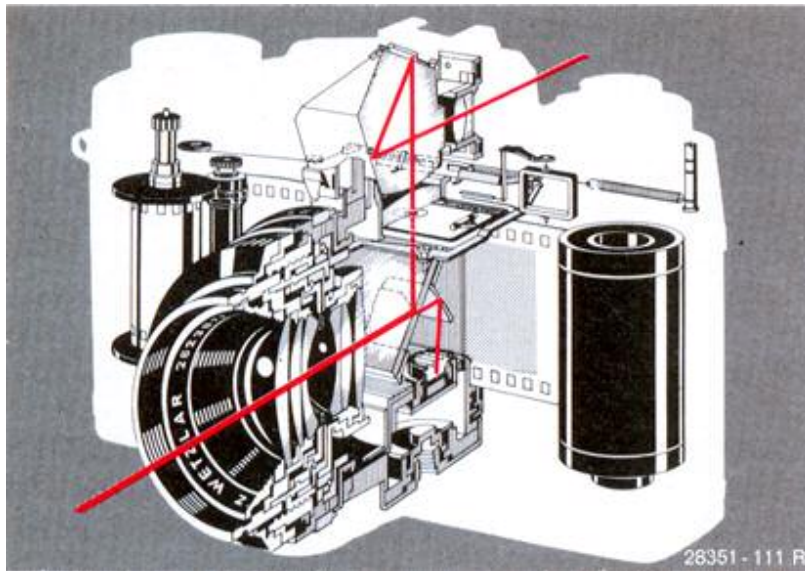

### Exposure meter

The exposure meter of the LEICAFLEX SL 2 measures through the lens at full aperture. Additional and therefore time-consuming operations are eliminated. 20% of the light coming from the lens is directed to the detector of the exposure meter via a cylindrical deflecting mirror arranged behind the hinged mirror. The detector is a CdS photo-resistor built into the bottom part of the camera and arranged so that no stray light influences the measurement. The outline of the measuring range of the exposure meter is indicated by the two semicircular markings top and bottom right on the

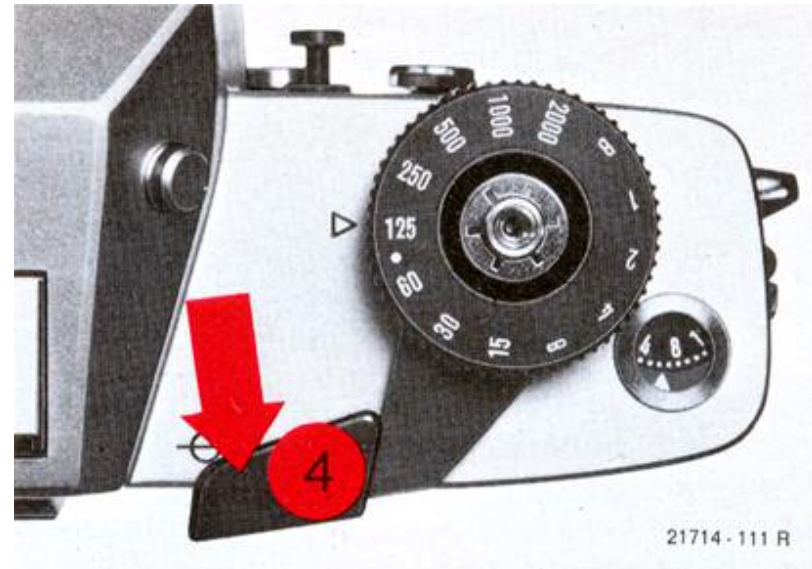

edge of the viewfinder image.

The exposure meter is switched on and off with the rapid transport lever (4). In the LEICAFLEX SL 2 the exposure meter is switched off when the rapid transport lever is parked against the camera body in the resting position. It is switched on when the rapid transport lever (4) is swung into the measuring position (in the LEICAFLEX SL 2 MOT special model the exposure meter is constantly switched on).

The measuring field of the exposure meter is exactly defined in the viewfinder by the large central circle. Thus the target area for the focal length of all the lenses



is outlined clearly and at the same size. The part of the subject representative of the exposure can be measured precisely. Unfavourable influences such as extremely bright or dark portions of the subject, open light sources, and other undesirable features can be eliminated by the measurement of an undisturbed area of the object representative of the total subject. In most cases a rule of thumb can be used: measure the feature you are focusing on. Generally do not measure extremes such as dark shadow portions, bright clouds, open light sources, or reflections on the water. Our special leaflet "Selective Light Measurement" No. 111-77 contains further details.



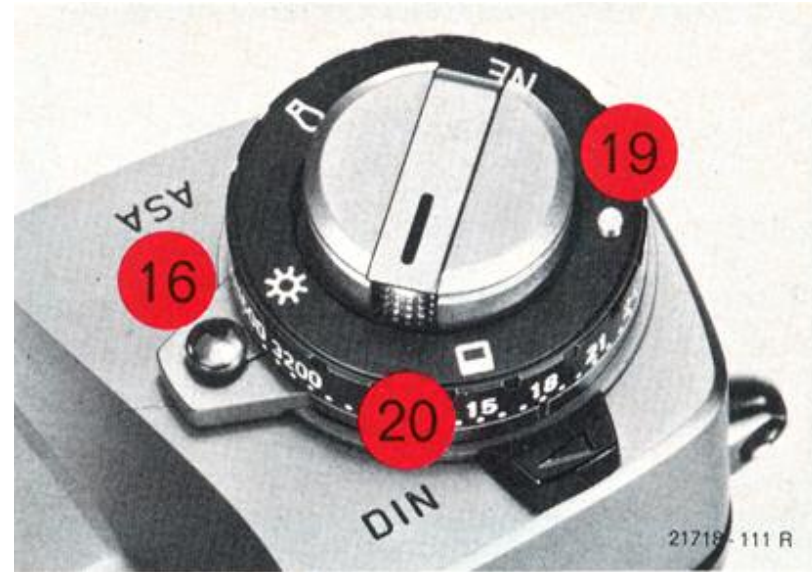

### Setting the film speed and -type

**Correct setting of the film speed is essential to correct exposure measurement.**

The setting ring (20) displays the DIN/ASA values. To set the value for the film in the camera depress the locking button (16) and simultaneously turn the ring until the desired number faces the corresponding index on the front (DIN) or back (ASA).



The film indicator disc (19) can be set at the following symbols to denote the type of film in the camera:

-  = Black-and-white film
-  = Daylight colour film
-  = Artificial-light colour film
-  = Colour negative film

The locking button (16) serves as index mark for the setting.

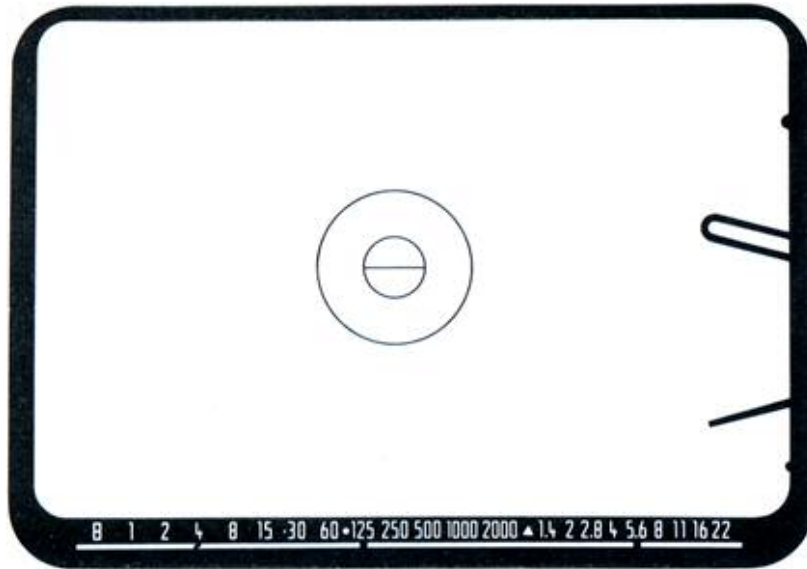

28362 - 111 R

### Setting the shutter speed

The pointers of the exposure meter appear on the right of the viewfinder field. The follow-pointer is coupled with the diaphragm setting ring (11) of the lens and the shutter speed dial (2) of the camera. To set the correct exposure the diaphragm setting ring (11) of the lens and/or the shutter speed dial (2) are adjusted. It is thus possible to select the desired shutter speed/lens stop combination at will:

The lens stop to vary the depth of field, the shutter speed to avoid camera shake or undesired movement blur. The shutter speed set on the shutter speed dial (left)

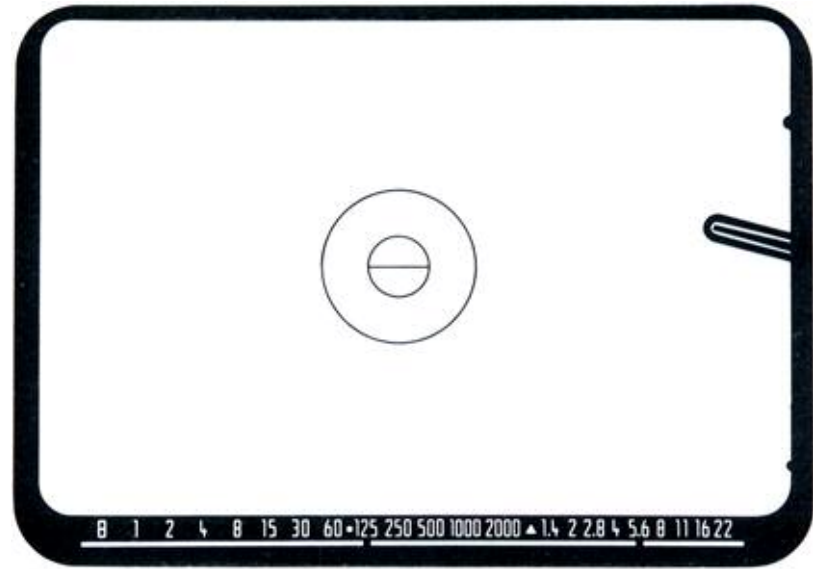

28362 - 111 R

and the pre-set lens stop (right) are displayed on the scale below the viewfinder image. When the exposure is set correctly the follow-pointer exactly brackets the measuring pointer.

### Measurement with working stop

Some accessories, such as extreme telephoto lenses, the ring combination for the close-up range, and the focusing bellows R have no automatic diaphragm. The exposure must be measured at the working stop. The deflection of the measuring pointer is influenced by a change in the lens stop. The follow-pointer is made to

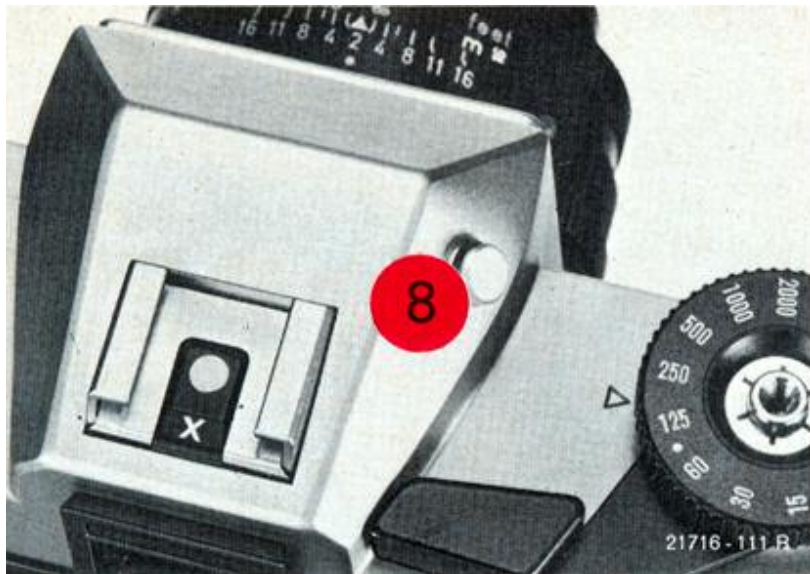

coincide with the measuring pointer by rotation of the shutter speed dial (2) of the camera. The reading for the lens stop in the viewfinder will be opposite ▲ in this case.

### Measuring in the limiting ranges

The high sensitivity of the exposure meter of the LEICAFLEX SL 2 permits precise exposure measurements even in very poor lighting conditions. To improve visibility the adjustment display on the right-hand margin of the viewfinder image is illuminated with the push-button (8). The lamp is supplied with current by a 1.35v mercuric oxide battery.

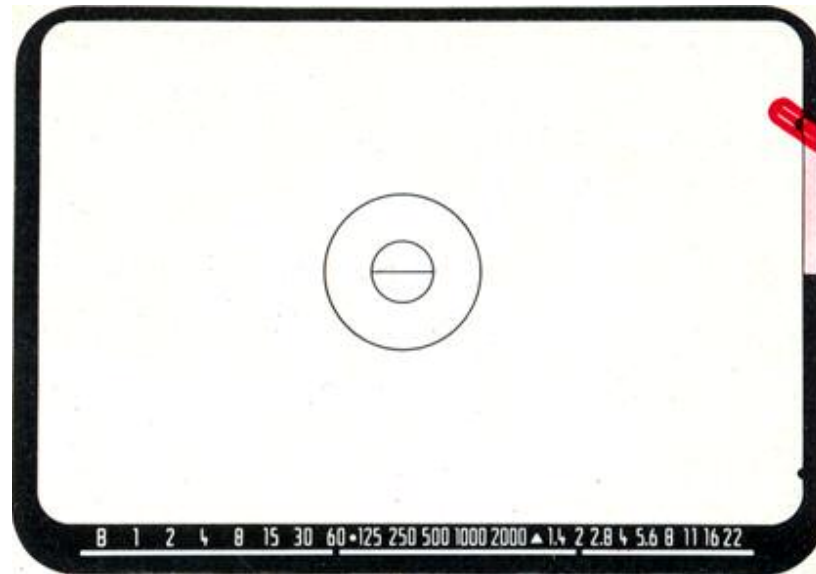

This is a Mallory PX 625 or an equivalent make. It is located underneath the cover (21), which is unscrewed when the battery has to be changed.

With short switching periods of 3 to 4sec duration the life of the battery is about 10 hours. Viewfinder illumination should therefore be switched on only when necessary.

### **Use of filters**

When light is measured through the lens the energy reduction owing to filters is generally allowed for automatically. But the various films have different sensitivities in the various spectral regions. Deviations from the measured exposure value can therefore occur with dense and extreme filters.

Thus an orange filter, for instance, requires an increase by about 1 stop value, red filters on average about 2 stop values. A completely accurate value cannot be given since the red sensitivity of black-and-white films varies a great deal.

With circular-polarizing filters as supplied

with our lenses measurement and settings can be carried out as with ordinary filters. With ordinary polarizing filters without circular effect the longest exposure is determined by rotation of the filter and set; now the desired effect is found and the exposure made.





### Testing the battery

The exposure meter has a 1.35v mercuric oxide battery as current source. The Mallory PX 625 or equivalent brands such as Varta Pertrix 7002 can be used. These batteries have an average life of 1-2 years even when the exposure meter remains switched on for prolonged periods.

The power of the battery can be tested as follows: hold the camera as for the horizontal format and look through the viewfinder. Depress the test button (15): the pointer of the exposure meter must be deflected at least as far as the lower semi-circular marking of the viewfinder field.

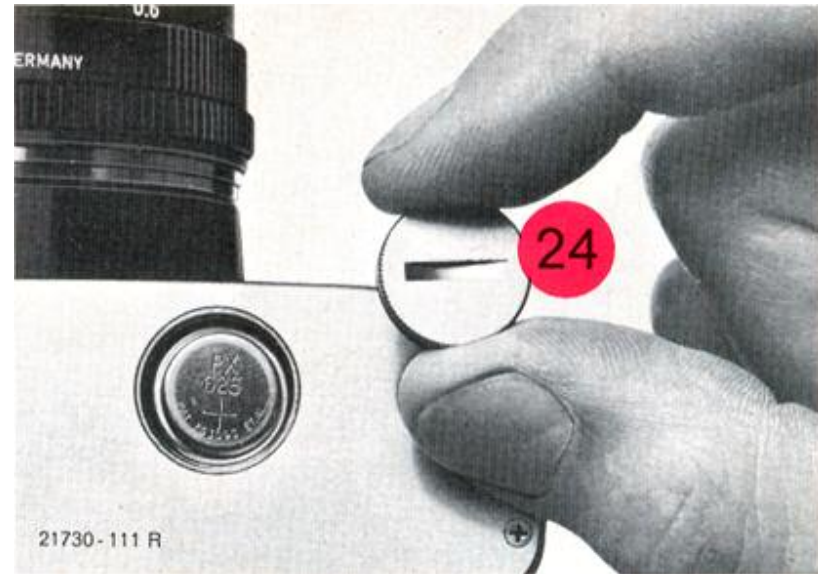

### Changing the battery

Unscrew the cover (24) on the underside of the body with a coin. This exposes the battery, which can now be exchanged. When inserting the new battery make sure that the engraved data are on top.

**The rapid transport lever (4)** transports the film through 1 frame with each full lever movement, winds the shutter and switches the film counter (1) to the next-higher number. It engages in a resting position (exposure meter switched off), in a measuring position, and in a readiness position.

**The shutter speed dial (2)** can be set before or after film transport and engages with a click opposite the engraved speeds. Intermediate values can be set as required and are fully operative except between  $\frac{1}{8}$  and  $\frac{1}{4}$ ,  $\frac{1}{30}$  and  $\frac{1}{60}$  sec. At the "B" setting the shutter remains open as long as the release button is depressed. Electronic flash units can be used at the speeds B, 1 to  $\bullet = \frac{1}{100}$  sec (see p. 23).

**The release button (3)** has a thread for cable releases. Pressure on the release button triggers the following camera functions in sequence:

1. The mirror is swung up.
2. The deflecting mirror for the exposure meter folds against the viewfinder mirror.
3. The lens diaphragm closes to the pre-set value.
4. The shutter operates.
5. The mirror returns into the optical path.

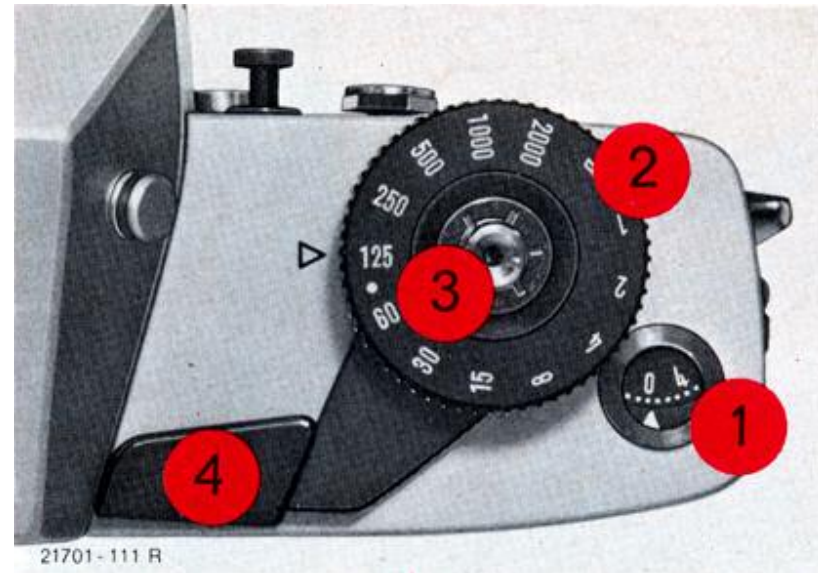

6. The deflecting mirror of the exposure meter returns to the measuring position.
7. The lens diaphragm reopens.



### The LEICAFLEX lenses

All LEICAFLEX-R lenses are of the same external design, i.e. the rotatable diaphragm pre-setting ring (11), the fixed ring with depth-of-field indication (12), and the distance setting ring (13) are arranged identically. The left hand thus becomes very easily accustomed to rapid and reliable operation with all focal lengths.



### Automatic diaphragm

All LEICAFLEX-R lenses are fitted with an automatic diaphragm. This means that the viewfinder image is viewed always — i.e. before and after exposure — at full aperture and thus maximum viewfinder brightness. Immediately before the exposure or when the depth-of-field button (6) is depressed the lens diaphragm is closed to the pre-set value.



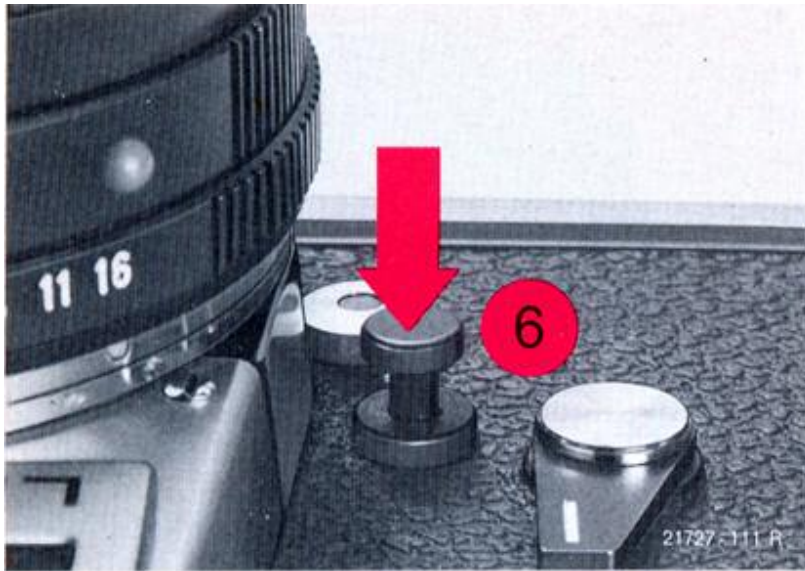

### Depth-of-field button

The LEICAFLEX SL 2 measures the exposure at full lens aperture. The depth-of-field button permits the assessment in the viewfinder of the depth of field to be expected with the pre-set stop-down. When the button (6) is pressed the lens diaphragm is closed to the preset value.

#### **Please note:**

During exposure measurement the button (6) must not be pressed.

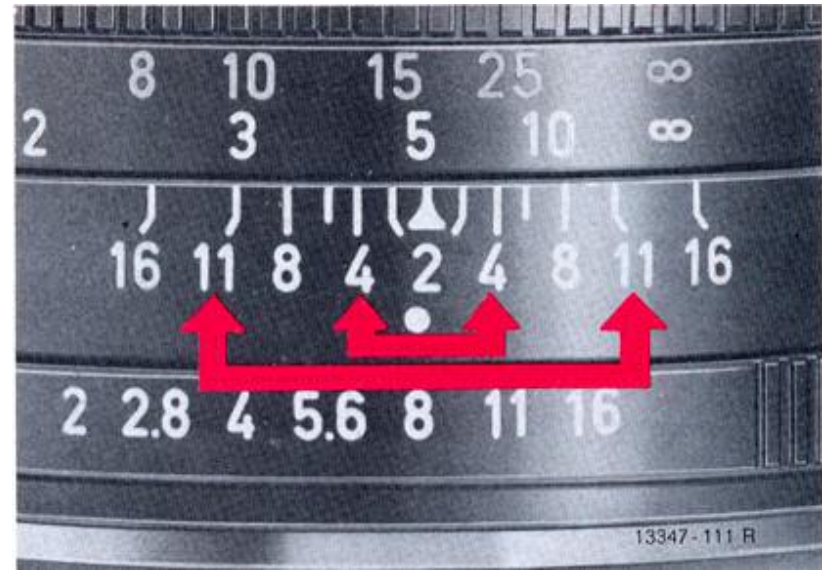

### Depth-of-field scale

The depth-of-field scale indicates the range of the depth of field for the object distance set on the distance setting ring.

If, for instance, you have focused the 50mm SUMMICRON-R f/2. lens on 5m, the sharpness will extend from 3m to about 20m when the lens is stopped down to f/11. If you stop down only to f/4, however, sharpness will extend from 4m to about 8m. Detailed information about depth of field with all focal lengths is contained in our Depth-of-field Table No. 110-57.





### **Lens hoods**

All LEICAFLEX lenses have their functionally designed lens hood. It should always be used as a matter of course, because it effectively protects the lens against stray light and flare as well as against raindrops and fingermarks.

On the wide-angle and standard lenses the lens hood is attached with the white dot facing white dot and locked by a clockwise turn. To unlock it, slightly raise the lens hood and turn it anti-clockwise to remove it. The lens hood of these lenses also serves as adapter for series filters.

On long-focal-length lenses the lens hood is permanently fixed and can be extended like a telescope.



### Series filters

With lenses of up to 50mm focal length inclusive the filters are inserted in the lens hood.

The lenses with telescoping built-on lens hood include a screwed-in adapter ring accommodating series filters. To insert the filter the adapter ring is unscrewed, the filter inserted, and the adapter ring replaced to secure it. The ring can be readily released if it is gripped only on one side and therefore "strainfree".

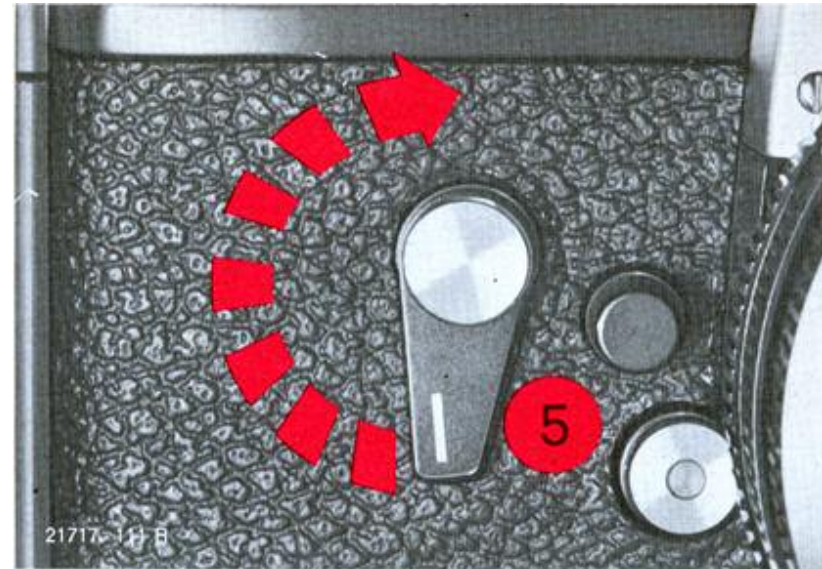

### Self-timer\*

The self-timer (delayed-action mechanism) operates with all shutter speeds. First the shutter is wound with the rapid transport lever (4). The self-timer is wound by a 180° turn of the lever (5) and started by means of the release button (3). Delayed action up to the exposure is about 10 sec. During this time the lever (5) returns to its end position. Shortly before it reaches this position the shutter is released.

If the lever (5) has been turned only through about 90° for winding, release cannot occur, even if the lever is turned back manually to its original position. Remedy: wind the self-timer completely and release by means of release button (3).

\* The LEICAFLEX SL 2 MOT special version does not include a self-timer.

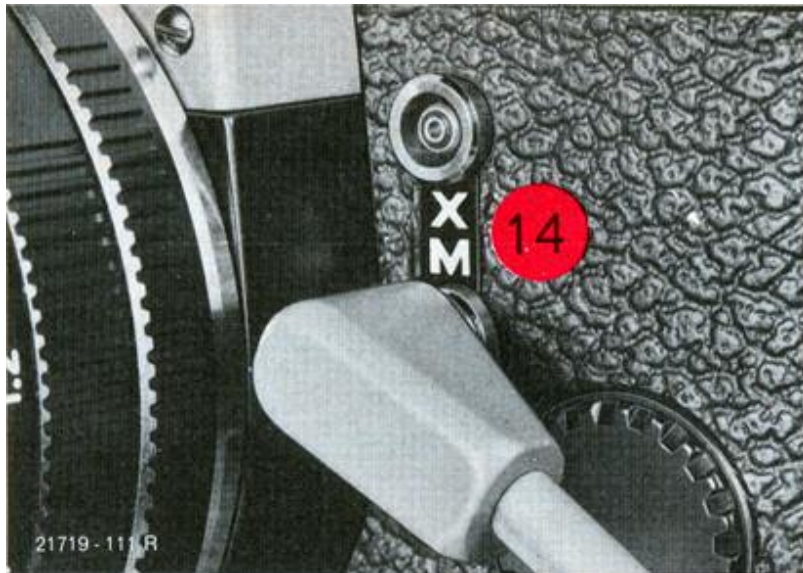

The table below contains information about the various possibilities.

### Flash synchronization

All the commercially available flash units with standardized flash plugs (co-axial plugs) or with accessory-shoe contact can be used on the LEICAFLEX SL 2.

The two contact bushes (10) are located in the front panel of the camera. Electronic flash units are connected to the upper contact bush marked "X", and expendable-flash units to the lower bush marked "M". Cordless flash units and adapters can be connected via the flash contact (X) in the accessory shoe (9).

Both types of flash can be used simultaneously.

### Flash Table

Electronic flash B→● ( $1/100$ )		Upper contact
Expendable-flash units	<b>M 2</b>	
	<b>AG 1</b> <b>AG 3</b> Flash cubes	$1 \rightarrow 1/60$
	<b>XM 1</b> <b>PF 1</b> <b>XM 5</b> <b>PF 5</b>	$1 \rightarrow 1/125$
	<b>GE 5</b> <b>25</b> <b>M 3</b>	$1 \rightarrow 1/250$
		Lower contact



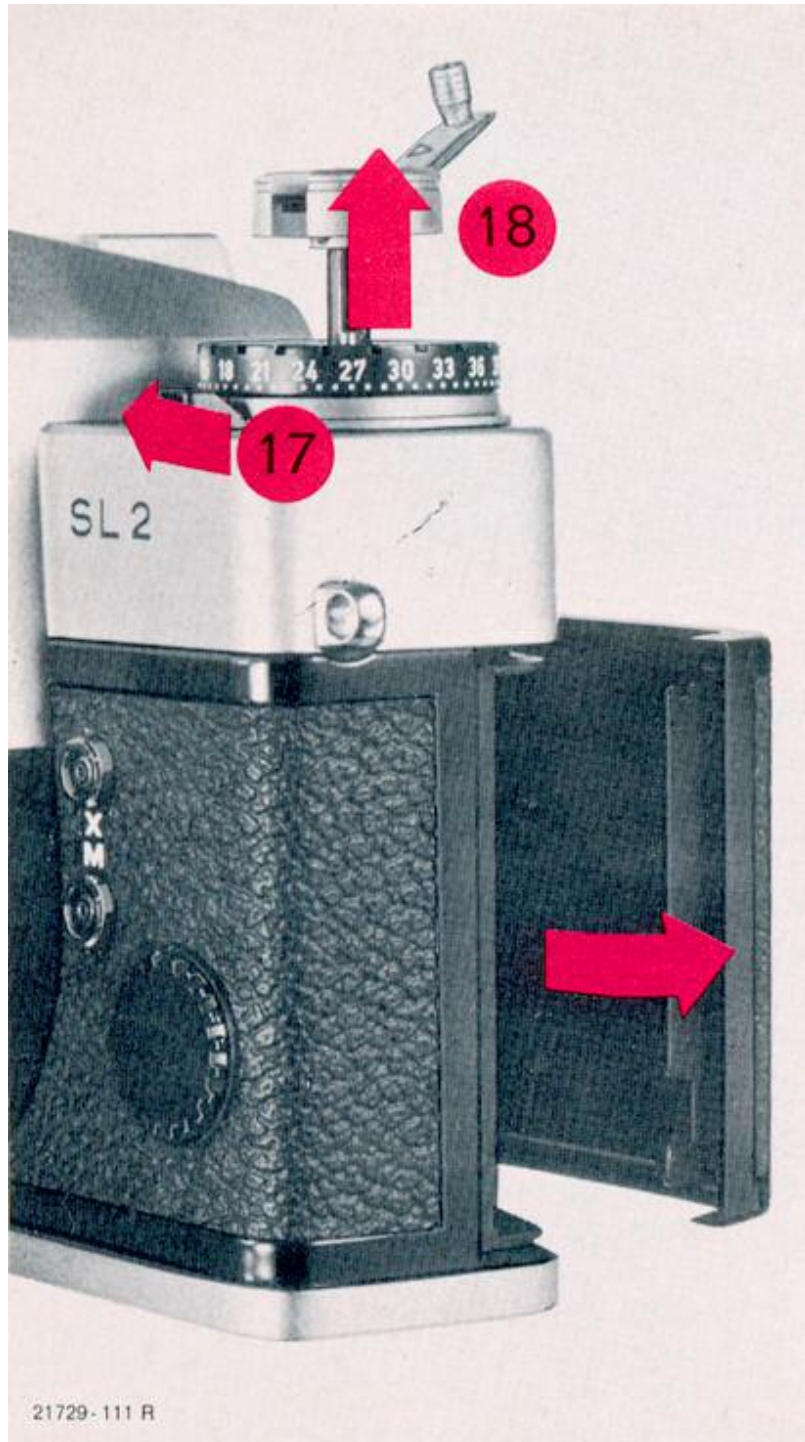

### Inserting the film

Open the camera back: push the clamp (17) in the direction of the arrow, hold it in position, and at the same time pull out the rewind crank (18). When the rewind crank is pulled out further the camera back will open automatically after overcoming a safety lock. The film counter (1) returns to "-2". Wind and release the shutter. Insert the film leader in one of the slots of the take-up spool as shown in the illustration. Please ensure that the film leader is gripped by at least one holder.

Insert the film cartridge in the empty space only now. Push in the rewind crank. The edge of the film must be parallel to the film guide, and the teeth of the transport sprocket must engage the perforation holes of the film during careful operation of the rapid transport lever.



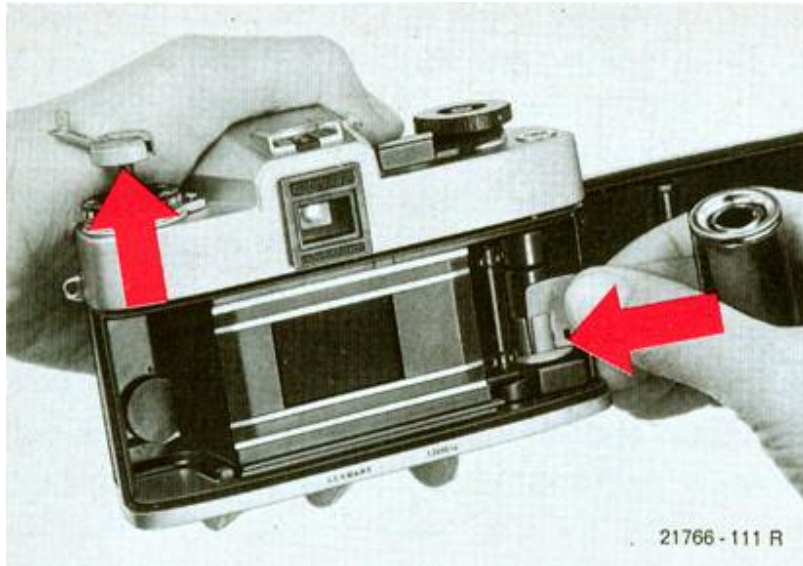

Close the camera by simply snapping the back shut; it engages automatically. Transport the film through one frame, release the shutter, and wind the rewind crank in the direction of the arrow to pull the film tight until you feel resistance. Transport

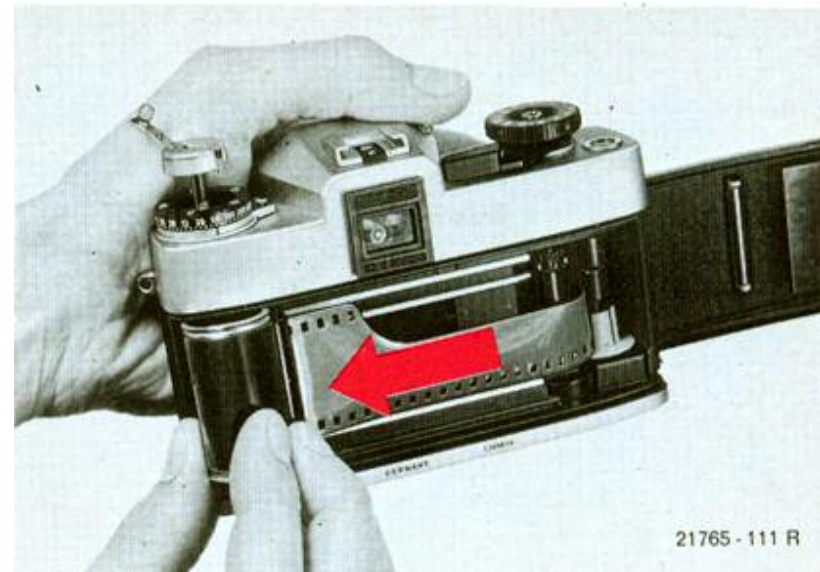

the film again and release the shutter. The film is correctly inserted and wound if the rewind crank rotates against the direction of the arrow during film transport. After the third transport the camera is ready for the exposure. The film counter (1) points at 1.



### Taking the film out

When the inserted film is completely exposed, increased resistance will be felt on the rapid transport lever (4). The film must be rewound into its cartridge as follows: push the button for the rewind release (27) on the underside of the camera body, turn the rewind crank out (18) and in the direction of the arrow until the film, after slight resistance has been overcome, is wound back into the cartridge after a further turn. Pull out the rewind crank (18) after releasing the clamp (17), open the camera body and take out the film cartridge. During rewinding the frame counter (1) moves backwards.

### Hints for the care of the LEICAFLEX and its lenses

Dust and fluff on the mirror is best removed — carefully — with a soft, dry sable brush degreased repeatedly in ether before and during the cleaning operation. The brush must, however, be absolutely dry during cleaning. Dust and fluff on the lower viewfinder screen should be removed only if the viewfinder image is very badly affected by it.

For this purpose we recommend a dry brush repeatedly degreased in ether. Avoid touching the viewfinder screen with the mount of the brush. Important: **Never blow into the mirror space**, as this may carry

dust into the interior of the camera.

A lens acts as a burning glass if it is pointed directly at the sun. Protect the interior of your camera by covering the lens with the lens cap, or keeping the camera in a case or in the shade. Each lens, in addition to its type, has its own Serial No. engraved on the front lens mount. Make a note of this as well as of the Serial No. of the camera, which you will find on the back of the baseplate of your LEICAFLEX. This may be of great importance in case of loss or theft.

A brownish-violet sheen indicates the high-quality coating of the LEICAFLEX lenses. These reflection-reducing layers vastly increase the brightness and brilliance of the picture.

Remove dust from the external surfaces of your lenses with a soft sable brush or with a clean, dry, soft piece of linen. Special cloths used for the cleaning of spectacles are not recommended; they are chemically impregnated and may therefore attack the glass of the lenses (glass used for spectacles differs in its composition from the optical glasses of high-quality camera lenses).

In unfavourable conditions, for instance on the beach, at sea, in subtropical climate etc. a colourless U.V. absorbing filter will

protect the front element of the lens from external damage by seawater spray and sand. Such an additional colourless and optically flat glass plate, i.e. a filter, may, however, cause undesirable reflections at certain angles of light incidence, especially in centre jour and artificial light. The lens hood, too, protects the lens against accidental fingermarks and raindrops.



21702 - 111 R



## Accessories

### Interchangeable lenses

In addition to the 50mm standard lenses you will have the choice of a large number of interchangeable lenses from 16 to 800mm focal length. The lenses from 16 to 250mm are equipped with automatic diaphragm. The 16mm fisheye-ELMARIT-R f/2.8, 24mm ELMARIT-R f/2.8 and 80-200mm VARIO-ELMAR-R f/4.5 lenses can be used on the LEICAFLEX SL 2 only, but not on earlier models because of their short intercept distance.

The 60mm MACRO-ELMARIT-R f/2.8 deserves your special interest; it can be used both as a standard and as a close-up lens, and, with the special adapter, even down to the 1:1 reproduction scale. This makes it a real universal lens.

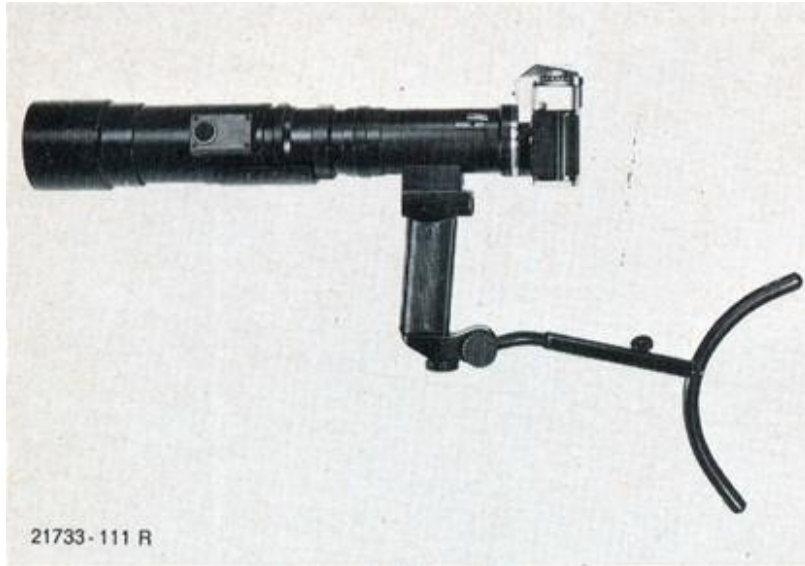

### **Follow-focus lenses**

The 400mm and 560mm TELYT-R f/6.8 very long-focal-length lenses have a precision parallel guide for rapid yet critical focusing, in which the front part of the lens mount is adjusted. The focusing mechanism can be released for focusing by means of a push-button and clamped at the desired setting. An outstanding feature of these lenses, in addition to their simple operation, is their light weight. They are supplied with an adjustable shoulder stock.



### **LEICA lenses on the LEICAFLEX**

All the LEICA<sup>®</sup> lenses suitable for the VISOFLEX<sup>®</sup> attachment can also be used on the LEICAFLEX. A special adapter (Code No. 14167) forms the bridge between the two LEITZ systems of 35mm photography. Vignetting of the viewfinder field does not affect the photographic exposures.

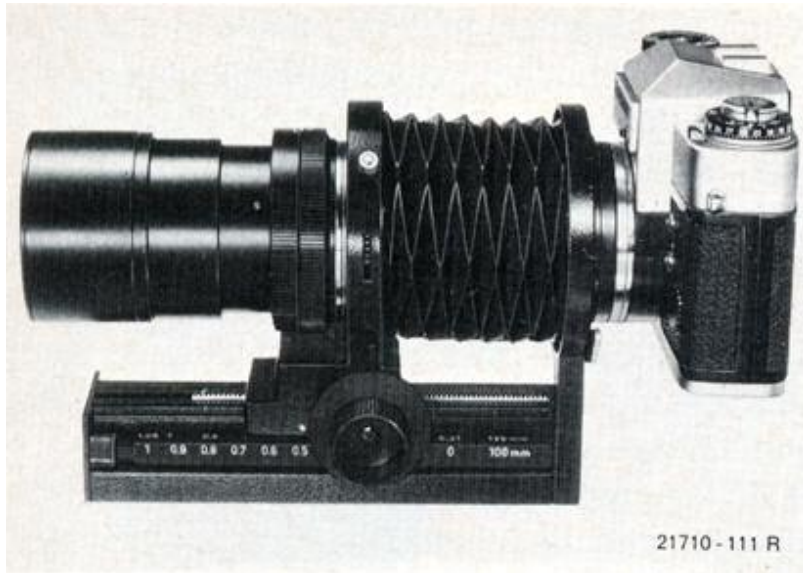

### **Focusing Bellows-R**

In conjunction with the 100mm MACRO-ELMAR f/4 special lens (Code No. 11 230) the Focusing Bellows-R (Code No. 16860) for the LEICAFLEX offers a continuous focusing range from infinity to 1:1. The 50, 60, 90, 135, 180, and 250mm lenses, too, can be used on the Focusing Bellows-R for the close-up range.



### **Motor for the LEICAFLEX SL 2 MOT**

The electric LEICAFLEX motor is used in conjunction with the LEICAFLEX SL 2 MOT special version. It makes exposure sequences of about 3 to 4 frames per second possible. All shutter speeds from 1 to  $\frac{1}{2000}$ sec can be set. The motor is powered by 10 NC batteries or 1.5v midget batteries (size R 6 in Germany, AA in USA). The list No. 120-46 is available on request.



### **Ring combination for the close-up range**

A three-part ring combination (Code No. 14159), which is used mainly in conjunction with the 50mm SUMMICRON-R f/2 standard lens, makes photography possible down to 1:1 reproduction scale. The combination can be expanded at will through the insertion of several middle rings. It can also be used in combination with 90, 135, and 180mm lenses.

With the twin-cable release the lens diaphragm can be closed semi-automatically.

### **ELPRO close-up attachments**

The ELPRO close-up attachments are achromatic supplementary front lenses which increase the focusing range and because of their achromatic correction also improve the image quality in the close-up range. Even medium stops produce outstanding sharpness. Exposure technique including exposure measurement is the same as in the normal focusing range. ELPRO close-up attachments are available for the 50mm SUMMICRON-R f/2, the 90mm lenses and the 135mm ELMARIT-R f/2.8.



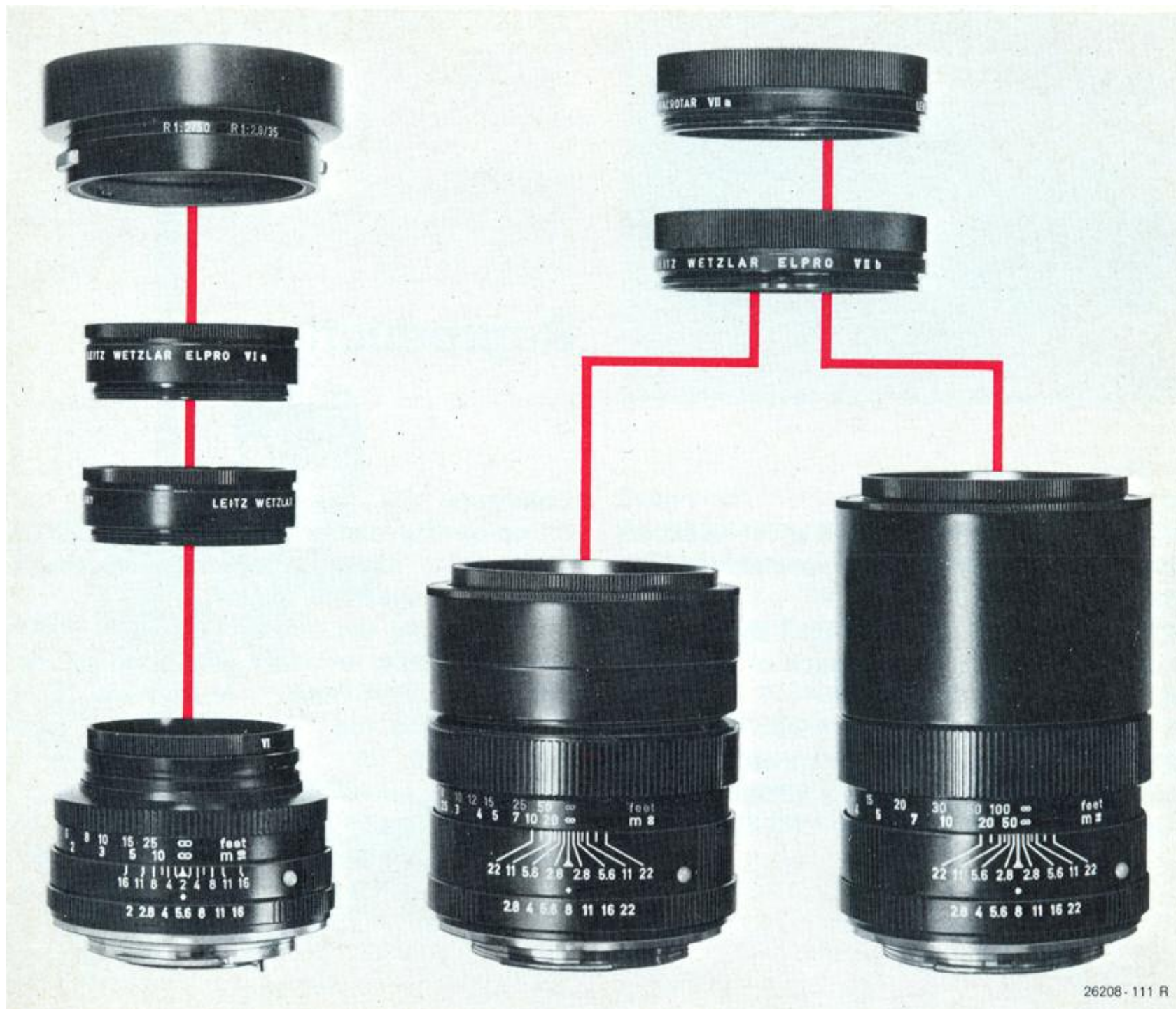

26208 - 111 R



### **Cases**

For the LEICAFLEX SL 2 with standard lens the ever-ready case (Code No. 14504) is recommended.

You can detach the front part by pushing up the press stud in the back of the case for unlocking.

In addition, combination holdalls are available for extensive camera outfits including several lenses and various accessories.

Further details: see List No. 120-42.

## **Reproduction**

### **Enlargers**

A top-quality camera such as the LEICAFLEX SL 2 requires reproduction equipment of comparable quality.

For enlarging we supply two such outfits with automatic focusing, well-tried for decades: the FOCOMAT® Ic, a pure 35mm enlarger, and the FOCOMAT lie, a combined outfit for all film formats up to 6 x 9cm.

Our Lists No.170-2 and 170-15 respectively contain detailed information.



## **Projection**

An extensive range of projectors is available according to requirements and purpose. They offer maximum operating convenience and versatile possibilities of extension.

The most outstanding common feature of all LEITZ projectors is optimum optical performance combined with traditional LEITZ precision.

Please ask for descriptive literature.

### **International LEITZ Warranty**

Our products are manufactured to special quality standards and tested by experienced specialists at the various stages of production. They conform to the International LEITZ Warranty for perfect quality and expert processing of the material, careful assembly of all components, and functional reliability of the design. The Warranty period for the mechanical and optical components is two years, for the electrical components one year from the date of purchase duly confirmed by the dealer.

A Warranty Card showing the camera No. is enclosed with every LEICAFLEX SL 2.

### **After-Sales Service**

In cases of damage our After-Sales Service is at your disposal.

Address:

**Ernst Leitz GmbH  
After-Sales Service Department  
D-6330 Wetzlar  
POB 2027  
Germany**

When abroad please contact the national LEITZ agency or the authorized LEITZ service workshop.

Within the period of warranty repairs are free of charge unless they are necessitated by improper handling. The warranty card, duly completed by your photo dealer, should, however, accompany the camera in every case. A list of LEITZ agencies and authorized service workshops is enclosed with every LEICAFLEX camera.



## Information Service



On request we shall inform you within the scope of our information service about new accessories and send you other important information.

Please use the appended coupon and send it to your national agency or directly to

**ERNST LEITZ GMBH**  
**After-Sales Service**  
**D-6330 WETZLAR**  
**POB 2020**  
**Germany**

after completing it and gluing it to a postcard.



\_\_\_\_\_  
Name and Surname

\_\_\_\_\_  
Address

\_\_\_\_\_  
Occupation

I am the owner of LEICAFLEX No. \_\_\_\_\_

and the following lenses: \_\_\_\_\_

I am the owner of the following LEITZ  
cameras: \_\_\_\_\_

I have been taking photographs since  
\_\_\_\_\_

I use my LEICAFLEX \_\_\_\_\_ % profession-  
ally in the following field(s): \_\_\_\_\_

Favourite non-professional subjects:  
\_\_\_\_\_  
\_\_\_\_\_

Reason for purchase: \_\_\_\_\_  
\_\_\_\_\_

**Journal**  
**"LEICA FOTOGRAFIE"**

Each LEICAFLEX SL 2 includes a coupon for sample copies of "LEICA FOTOGRAFIE", the topical journal of 35mm technique. It is published in German, English, and French. Please send the completed coupon directly to:

**Umschau-Verlag**  
**D-6000 Frankfurt/Main**  
**Stuttgarter Strasse 18-24**  
**Germany**

## Accessories

a) <b>Interchangeable lenses</b>	Code No.	b) <b>Close-up focusing devices</b>	Code No.
*16mm FISHEYE-ELMARIT-R f/2.8	11 222	Focusing Bellows-R	16 860
21mm SUPER-ANGULON®-R f/4	11 813	100mm MACRO-ELMAR® f/4	11 230
*24mm ELMARIT®-R f/2.8	11 221	Ring combination for the	
28mm ELMARIT-R f/2.8	11 204	close-up range	14 159
35mm SUMMICRON®-R f/2	11 227	ELPRO 6a for 50mm f/2 lenses	16531
35mm ELMARIT-R f/2.8	11 201	ELPRO 6b for 50mm f/2 lenses	16532
35mm PA-CURTAGON®-R f/4	11 202	ELPRO 7a for 90 and 135mm lenses	16533
50mm SUMMILUX®-R f/1.4	11 875	ELPRO 7b for 135mm f/2.8 lens	16534
50mm SUMMICRON-R f/2	11 228		
60mm MACRO-ELMARIT-R f/2.8	11 203	<b>c) Cases</b>	
90mm SUMMICRON-R f/2	11 219	Ever-ready case	14504
90mm ELMARIT-R f/2.8	11 239	Combination case for camera	
135mm ELMARIT-R f/2.8	11 211	with up to 3 lenses	14824
180mm ELMARIT-R f/2.8	11 919	Universal holdall with insert 3	14809
250mm TELYT®-R f/4	11 920		
400mm TELYT f/6.8	11 960		
560mm TELYT f/6.8	11 865		
45-90mm ANGENIEUX-ZOOM f/2.8			
	On request		
*80-200mm VARIO-ELMAR-R f/4.5	11 224		
800mm TELYT-S f/6.3	On request		
800mm ROKKOR f/8 Minolta reflecting lens with LEICAFLEX connection			
	Available through		
	Minolta Sales Organization		

\* Can be used only on the LEICAFLEX SL 2

**List of brochures**

Depth-of-Field Table	111-57
Close-up devices for the LEICAFLEX	160-12
60mm MACRO-ELMARIT-R f/2.8	111-100
800mm TELYT <sup>®</sup> S f/6.3	120-48
Combination cases	120-42
FOCOMAT <sup>®</sup> Ic	170-2
FOCOMAT IIc	170-15
PRADOVIT RC	310-74
PRADOVIT <sup>®</sup> -COLOR	310-49



**Symbol of Optical Precision**

<sup>®</sup> = Registered Trademark

Design subject to alterations without notice.

**ERNST LEITZ GMBH D-6330WETZLAR**

Subsidiary: Ernst Leitz (Canada) Ltd., Midland, Ont

List

**11-94/Engl.**

Printed in Germany X/74/FDX/SD